

2510H/2510CH SERIES

2.54mm PITCH WIRE TO BOARD CONNECTOR

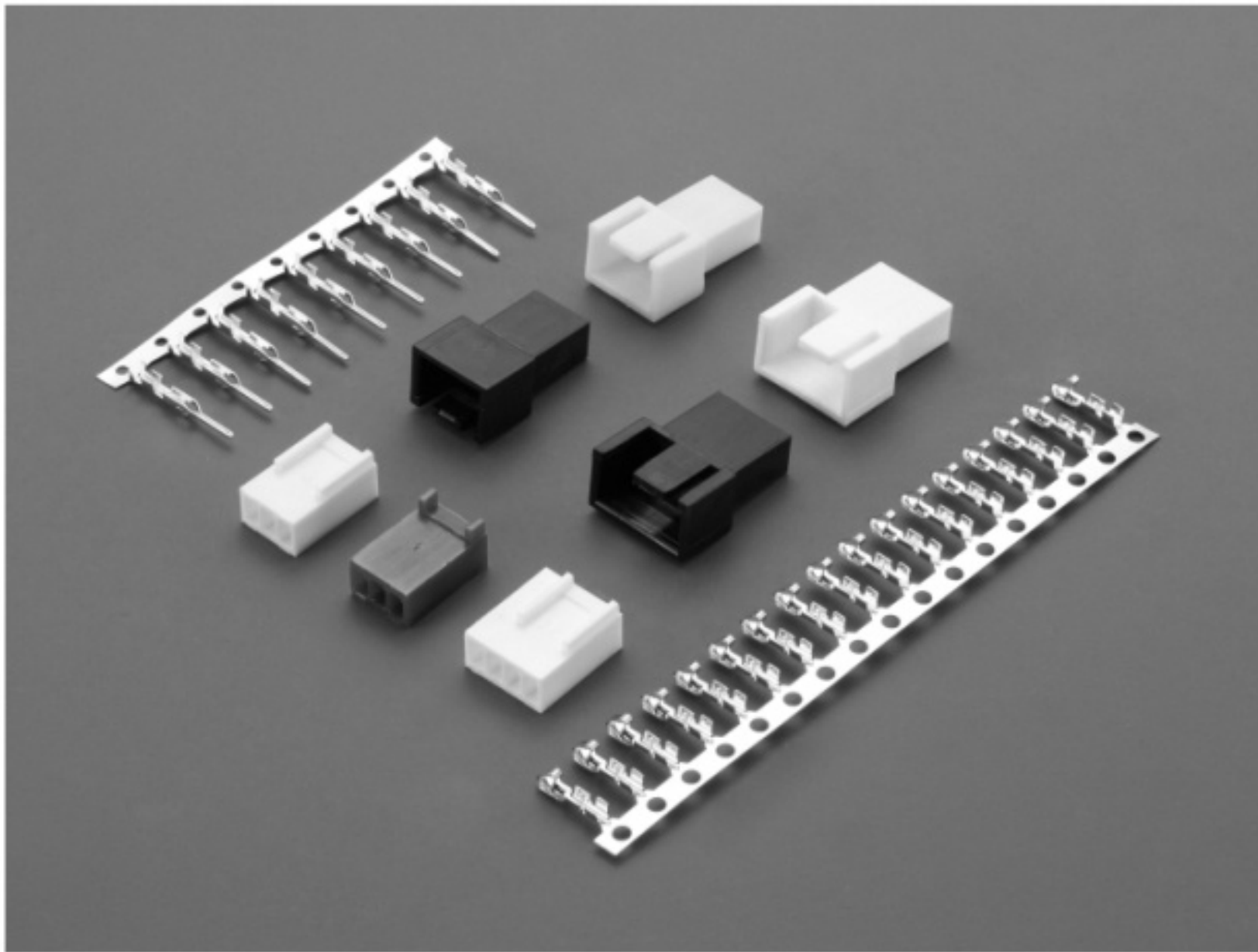

Specifications

Current rating: 3A AC,DC

Voltage rating: 250V AC,DC

Temperature range: -25°C to + 85°C
(including temperature rise)

Contact resistance: Initial value/10m Ω Max.
After environmental testing/20m Ω Max.

Insulation resistance: 1000 M Ω Min.

Withstanding voltage: 1000V AC/minute

Applicable wire: AWG#22-#28

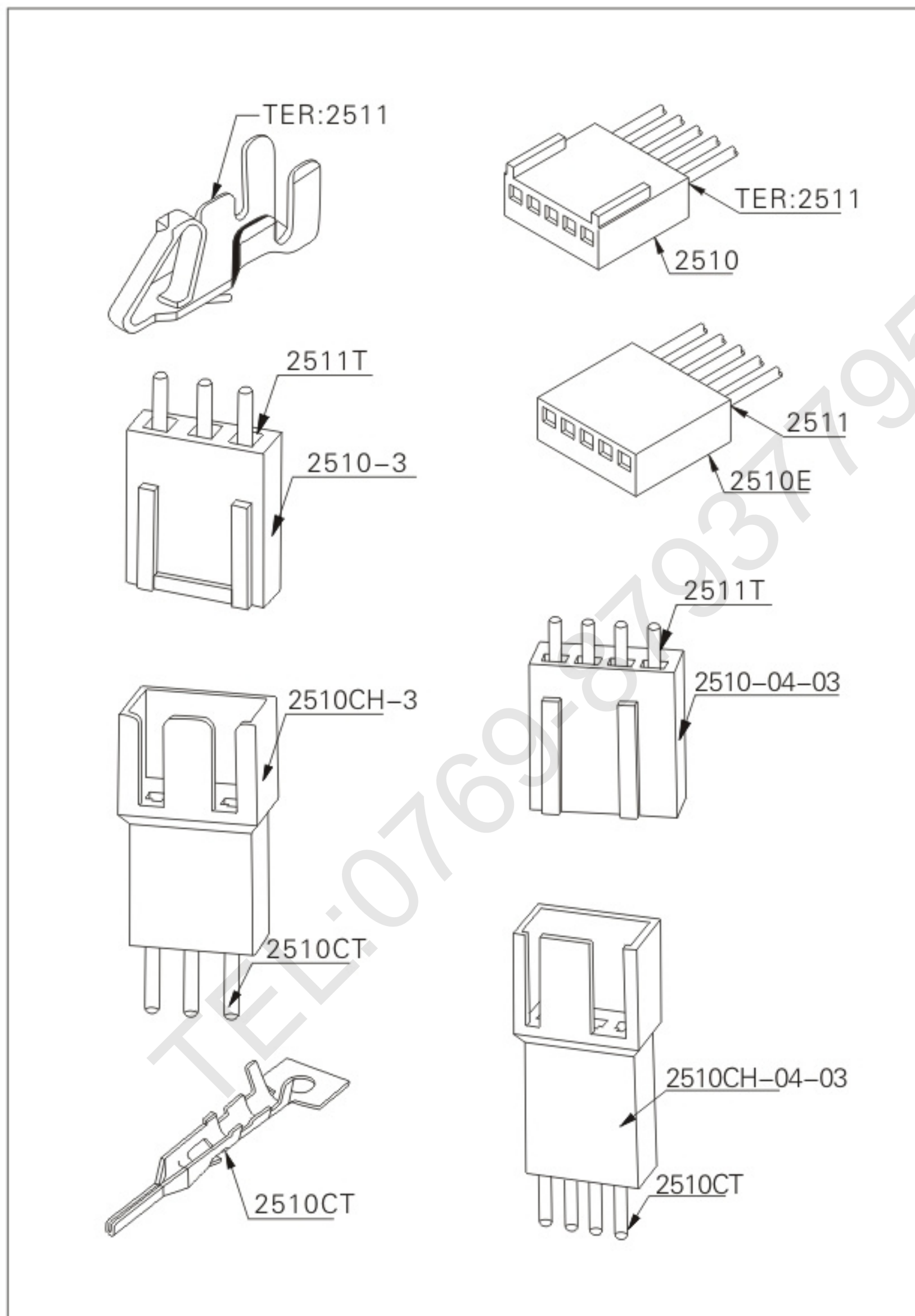

Assembly layout

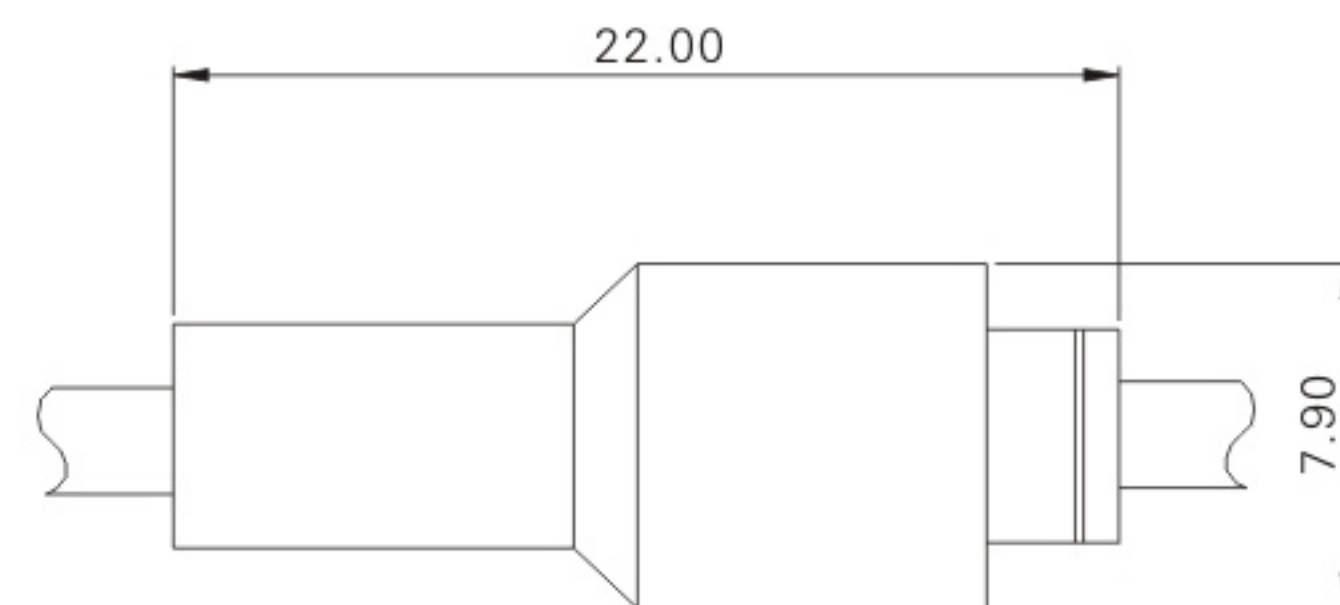

2510CT (2.54mm pitch crimp terminal)

Reference Informations:

*Thickness: 0.2mm

*Mates With: 2510CH series Housing

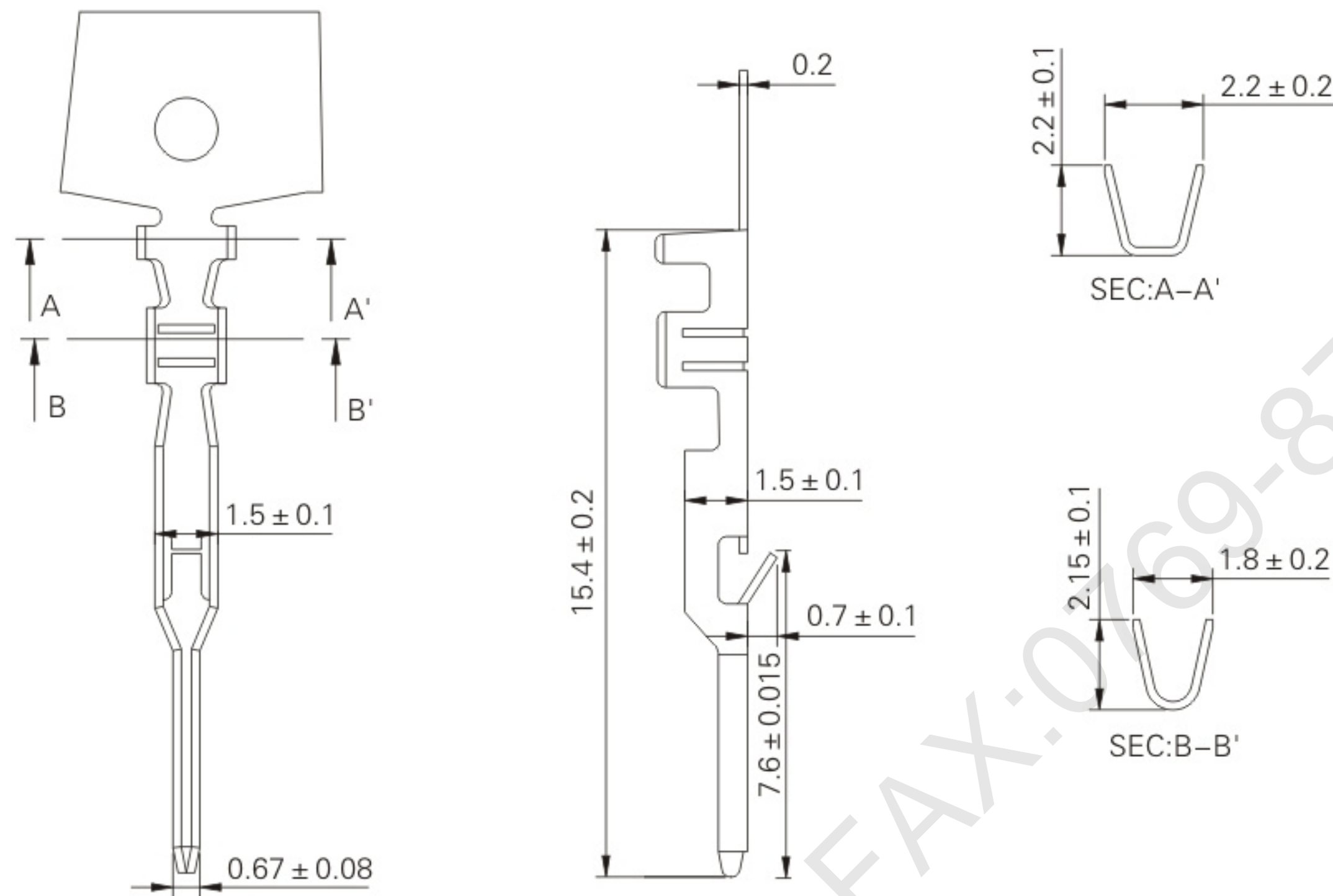

Ordering Information & Specifications

Unit: mm

Part No.	Wire Range	Insulation O.D.	Material	Finish	Qty/reel
2530CT-2	AWG#24-#26		Brass	Tin-plated	10,000

2510CH (2.54mm pitch crimp housing)

Reference Informations:

*Mat'l: Nylon 66 UL94V-0

*Accepts With: 2510H

*Mates With: 2510CT

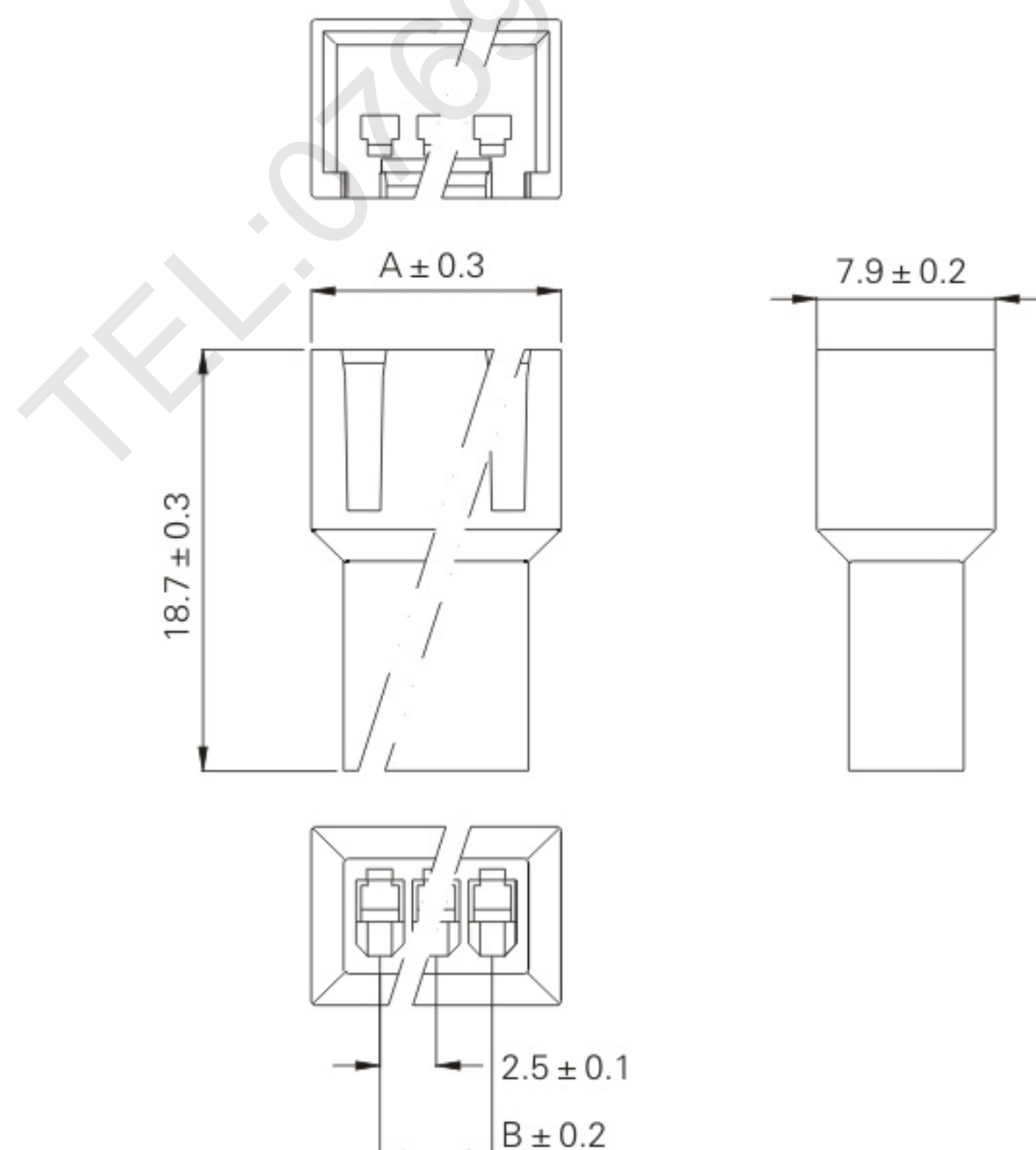

Ordering Information & Dimensions

Circuits	Part No.	DIM.(mm)	
		A	B
02	2510CH-02	8.60	2.50
03	2510CH-03	11.00	5.00
04	2510CH-04	13.6	7.50

2510CH-04-03 (2.54mm pitch crimp housing)

Reference Informations:

*Mat'l: Nylon 66 UL94V-0

*Mates With: 2510CT

*Accepts With: 2510H

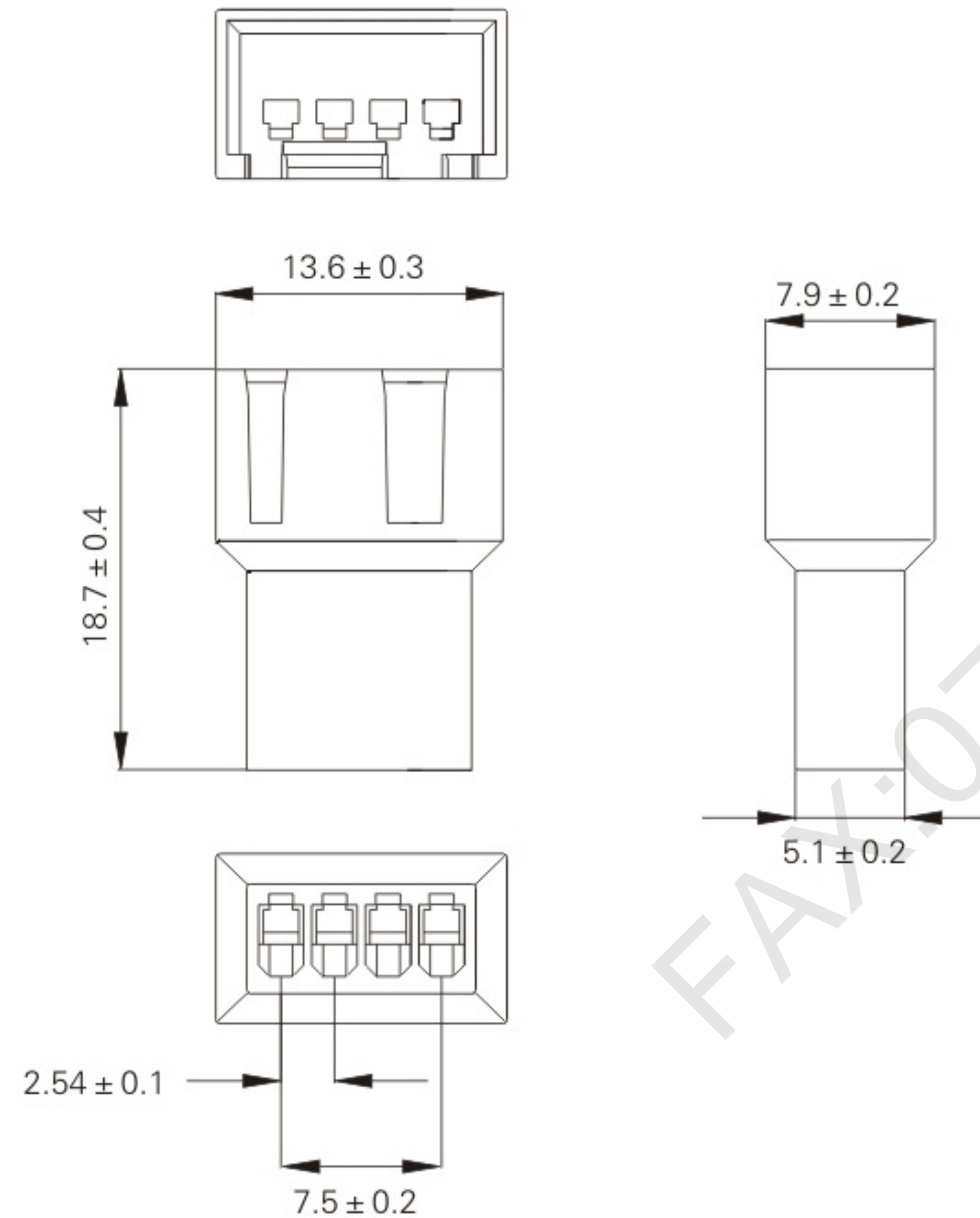

2510H-04-3 (2.54mm pitch crimp housing)

Reference Informations:

*Mat'l: Nylon 66 UL94V-0 or 94V-2

*Mates With: 2511 series Terminal

*Accepts With: 2600PS/PR or PRM series Wafer

